

SBK - K 28 / 38

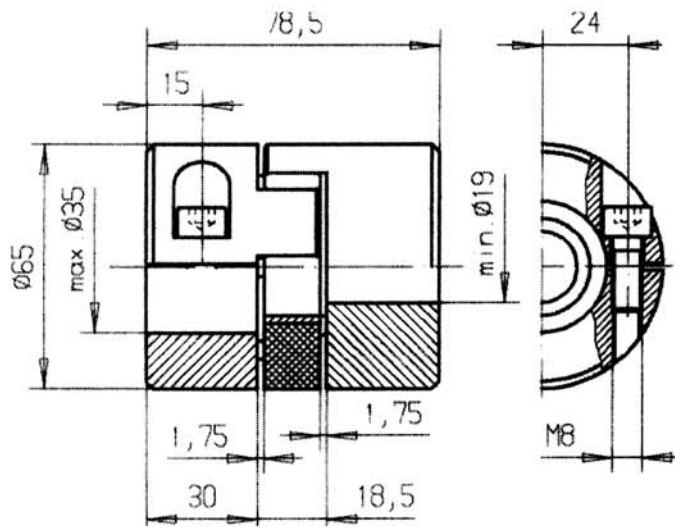

Nennmoment: (Nm)	160
Maximalmoment: (Nm)	320
Stat.Federsteife: (Nm/rad)	3488
Dyn.Federsteife: (Nm/rad)	10314
Radialfedersteife: (N/mm)	3200
Wellenversatz: (mm)	
Axial	1,5
Lateral	0,11
Winklig (°)	0,9
Anzugsmoment (Schrauben Nm)	25

SBK - K 38 / 45

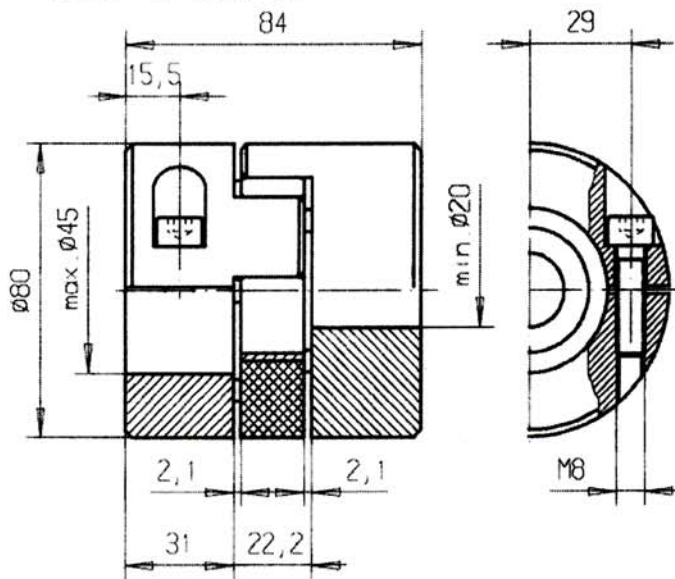

Nennmoment: (Nm)	325
Maximalmoment: (Nm)	650
Stat.Federsteife: (Nm/rad)	7160
Dyn.Federsteife: (Nm/rad)	21486
Radialfedersteife: (N/mm)	4400
Wellenversatz: (mm)	
Axial	1,8
Lateral	0,12
Winklig (°)	0,9
Anzugsmoment (Schrauben Nm)	25

SBK - K 42 / 55

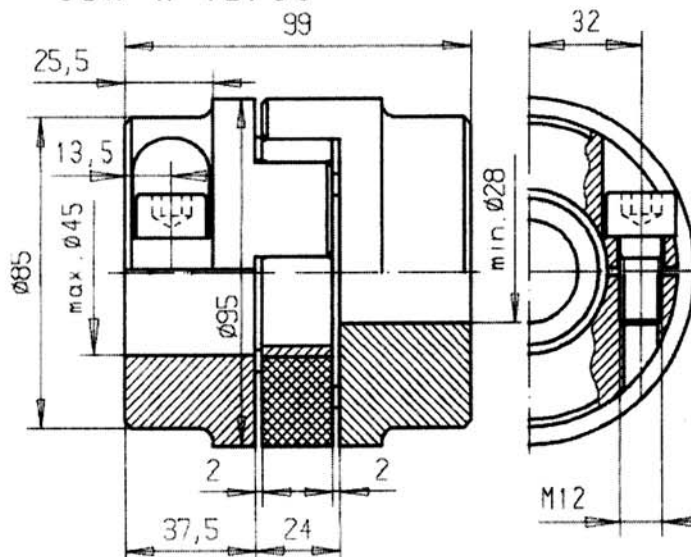

Nennmoment: (Nm)	450
Maximalmoment: (Nm)	900
Stat.Federsteife: (Nm/rad)	19200
Dyn.Federsteife: (Nm/rad)	48000
Radialfedersteife: (N/mm)	5570
Wellenversatz: (mm)	
Axial	2
Lateral	0,14
Winklig (°)	0,9
Anzugsmoment (Schrauben Nm)	120